

NEW in 2020

# FTVN Series



Products you need  
from people who care

## Next Evolution of the FTV Fire Tube Boilers

- Vertical down fired stainless steel heat exchanger for exceptional efficiency and durability
- Modulating Combustion is 10:1
- Models up to 96% AFUE
- Wi-Fi on board for remote control and monitoring
- Heat Only and Combi versions available
- Integrated ECM pump and DHW diverter valve on all models
- Small zone valve systems may not require an additional pump or a low loss header
- Easy service access and quick component connections
- For Indirect DHW applications, internal diverter valve eliminates need for indirect pump



**95-96% AFUE**



**15 YEAR / 5y**  
PRIMARY HEAT EXCHANGER PARTS  
**WARRANTY**

## | AIC® Vertical Fire Tube heat exchanger

The NTI FTVN series uses a fire tube heat exchanger from AIC®, the world leader in fire tube technology. With a rugged construction from SA-240 S43932 Chromium stainless steel, produced in a state-of-the-art automated production facility, the heat exchanger exhibits the highest quality and durability.

The down-fired fire tube design makes it highly resistant to combustion chamber fouling – an issue for many other condensing heat exchanger types. Through accelerated lifecycle testing and vast field experience, the FTVN heat exchanger has proven to resist scale and magnetite formation – an issue that can plague some other fire tube heat exchangers.

The innovative dimpled tubes extract more of the heat from the flue gases, while maintaining a compact size without the need for tube inserts that degrade over time.



## | Exclusive NTI NET Wi-Fi Connectivity

### **Wi-Fi on board for remote access and monitoring**

Every unit is equipped with an embedded Wi-Fi gateway to allow the boiler to be connected to the internet and remotely accessible via “NTI Remote Contractor”, NTI’s web based tele-diagnostic service. The web based service provides registered “NTI Remote Contractors” with an easy way to manage their NTI boiler installations, while providing remote access to the brain of each connected boiler.

Service companies can monitor all their installed Wi-Fi NTI boilers with the NTI Web App. Thanks to the remote diagnostic system and 24/7 remote monitoring, it is now possible to be closer to your customer than ever before.

With this access, the technician can remotely view all of the boiler data (readings, settings, status, history, statistics, etc.) in real time, and in an easy to understand format. If you need to make a setting adjustment, no problem. All settings are remotely adjustable, just modify the setting and submit. The service will make the change while tracking who made the change and when.

Customer reports of inconsistent heat or hot water can easily be investigated remotely by viewing the history of all boiler errors or irregularities; saving you a trip to the job site. Blocking errors promptly triggers an email notification, allowing you to know of a problem before the customer does.

### **Hot water**

The FTVN is offered in two versions: Combi and non-Combi. Both versions incorporate robust hydraulic components fabricated from solid brass, and a reliable 3-way valve to divert boiler water for space heating or domestic hot water heating.

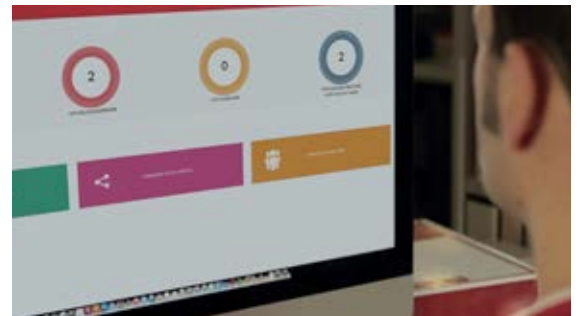



The built-in circulating pump and the 3-way valve eliminate the need for an external DHW pump when a non-Combi model is paired with an indirect water heater. The large free flowing passageways ensure that domestic hot water generation is maximized.

In Combi models, domestic hot water is generated via a high-performance brazed plate heat exchanger, which easily transfers all of the boiler's output energy to usable domestic hot water; while a smart comfort function greatly reduces faucet wait times. Tap demands are recognized by the DHW flow sensor, which is protected by an integrated and easy-to-service DHW filter.



## Easy service access and quick component connections

The FTVN has been designed with service in mind. The components are each easily removable, and the space within the cabinet has been maximized so that your hard working hands have space to work. The swing down control box also enhances serviceability, making all major components easily accessible.

## Integrated high efficiency ECM primary pump

The FTVN features a powerful high efficiency ECM pump, to quietly circulate water through the boiler and boiler primary loop, or boiler and indirect water heater loop – AN EXTERNAL DHW PUMP IS NOT REQUIRED. When the application does not call for primary/secondary piping, then an external CH pump may not be required, thanks to the boiler's built-in pressure bypass valve. (check the Installation and Operating Manual for applicability)



**OPTIONAL FLOOR MOUNT KIT #86998**

### Additional technical features:

- Two adjustable and independent heating zone inputs (three inputs with an NTI zone controller)
- Optional NTI 3-Zone Pump/Valve Controller communicates directly with boiler control
- Integrated pressure bypass valve – potentially eliminates the need for primary/secondary piping
- Outdoor sensor included for adjustable outdoor reset or access weather via a Wi-Fi connection
- Cascade up to 8 boilers
- Field convertible to LP kit included
- Extremely quiet sealed cabinet design
- Optional 4-20mA or 0-10V input
- CH and DHW pump outputs
- Integrated easy-to-service DHW filter
- Error history included
- Indirect water heater ready – either with tank thermostat or sensor
- High energy ignition transformer

## DEPENDABLE BY DESIGN

At NTI, we manufacture all our boilers to the highest industry standards. Our in-factory Quality Control tests are the most rigorous in the industry. Every FTVN boiler is factory live-fire tested and calibrated for optimal performance. Our limited lifetime warranty provides you with the assurance of years of worry-free operation and our Technical Support is second-to-none.

## Dimensions

A	Central Heating Outlet
B	DHW Outlet (combi or indirect)
C	Gas Inlet
D	DHW Inlet (combi only)
E	Central Heating Inlet
F	Condensate Drain

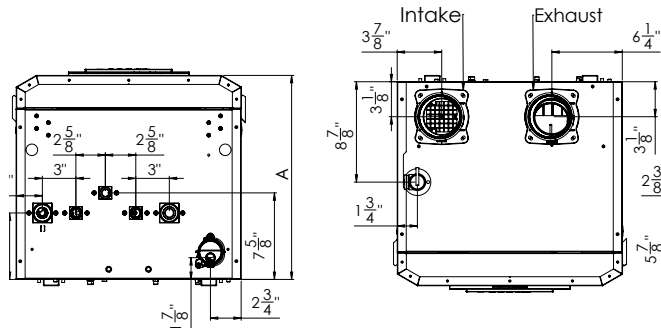

Dimensions (A) - FTVN085 & 110 = 16.5" FTVN150 & 199 = 18"

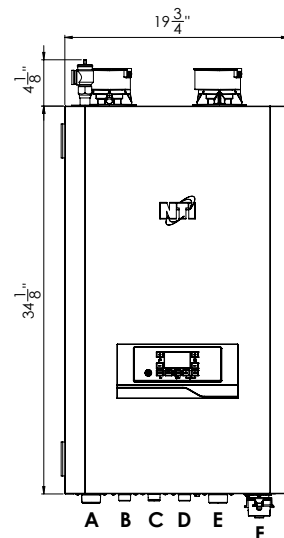

## Specifications

	FTVN085	FTVN110	FTVN150	FTVN199	FTVN110C	FTVN150C	FTVN199C
Input Heating MBH	8.5 - 85	11 - 110	15 - 150	19.9 - 199	11 - 110	15 - 150	19.9 - 199
Input (DHW Combi)							
AFUE	96%	95%	95%	95%	95%	95%	95%
Heating Capacity (MBH)	79	101	138	184	101	138	184
Net AHRI Rating (MBH)	69	88	120	160	88	120	160
Combi Water Flow at 77° FT Rise	N/A				2.7 GPM	3.6 GPM	4.8 GPM
Weight (lbs)	95	95	105	116	95	106	117
Water Content (Gallons)	1.4	1.4	2.0	2.8	1.5		2.8
Water Connections (Heating)	1-1/4" NPT-M						
Water Connections (DHW)	3/4" NPT-M						
2" Inlet & Exhaust Distance	100' max			N/A	100' max		N/A
3" Inlet & Exhaust Distance	150' max				150' max		150' max
Gas Connection All Models	3/4" Male						

For more information contact your local NTI representative or visit [ntiboilers.com](http://ntiboilers.com). Information at time of printing, and subject to change without notice.



DISTRIBUTED BY:

**NTI Boilers Inc.**  
 30 Stonegate Drive, Saint John  
 New Brunswick E2H 0A4 Canada  
 Tel: 506-657-6000  
 Toll-free: 800-688-2575  
 Fax: 506-432-1135

[ntiboilers.com](http://ntiboilers.com)